

Problema de examen del 31.01.07

Una obra de promoción privada, que inició hace 2 meses, no llegó a la preventa esperada, por lo que los inversionistas se ven forzados a solicitar un crédito bancario para poder enfrentar la financiación de los trabajos y cumplir con las fechas contractuales de entrega de las unidades comprometidas.

Dado que dicho crédito recién estará disponible dentro de cuatro meses, se nos solicita, manteniendo el plazo final de obra y las tareas críticas tal cual están en el cronograma vigente, disminuyamos el ritmo financiero de obra en lo posible, hasta el mes 6, sin detener la misma.

Datos:

Tarea	Duración	Le antecede	Le sigue	Precio U\$S
A	5	n	D,E	55000
B	4	n	E	60000
C	2	n	F,J	70000
D	2	A	G	22000
E	4	A,B	I,H	50000
F	5	C	I,H	75000
G	3	D	I	30000
H	5	E,F	n	50000
I	1	E,F,G	n	30000
J	8	C	n	84000

Se pide:

- 1- Plazo total
- 2- Cronograma de obra.
- 3- Modificación solicitada alterando la menor cantidad de tareas
- 4- Verificación de camino crítico y evaluación de posibles consecuencias en obra, de la modificación planteada

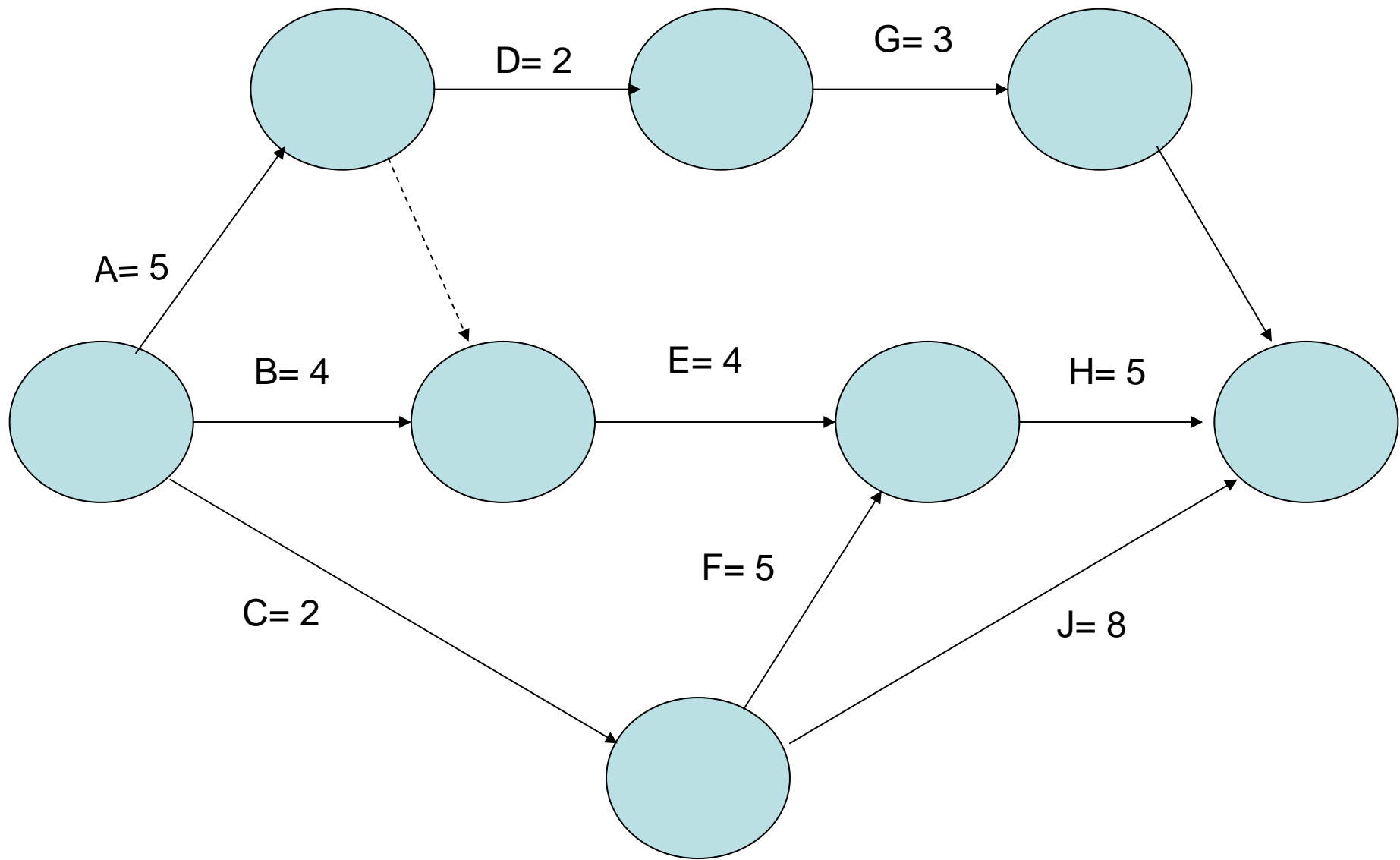

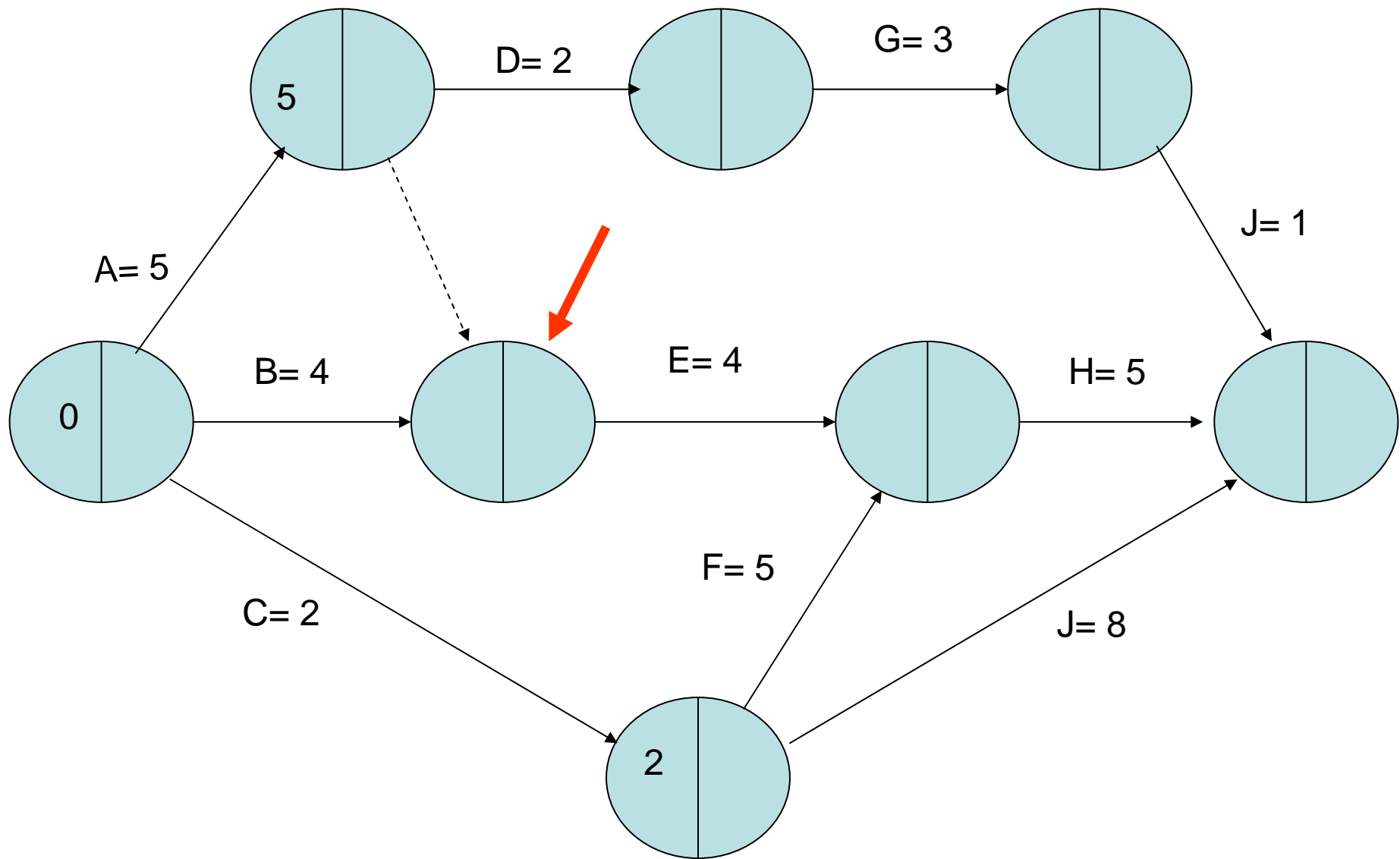

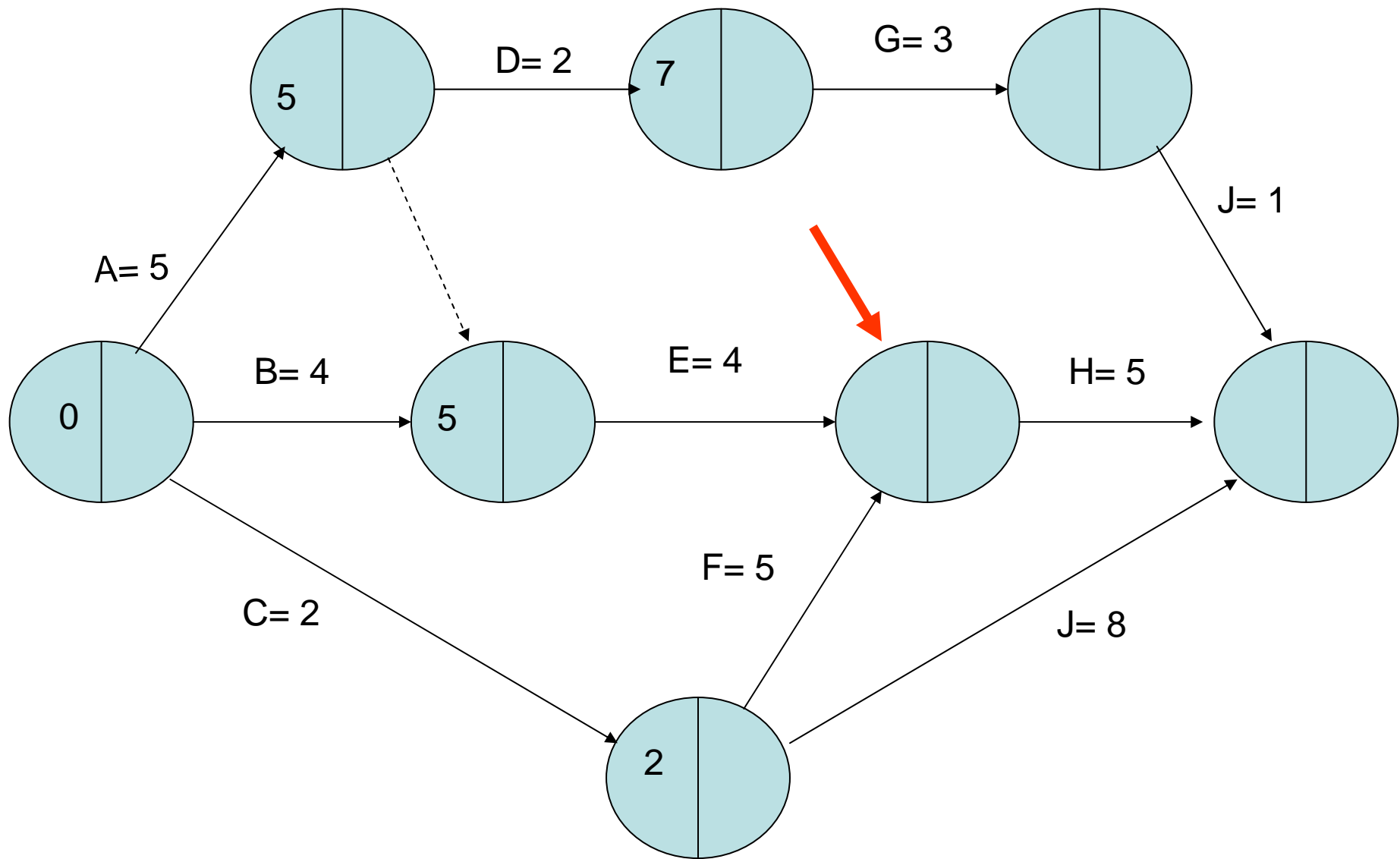

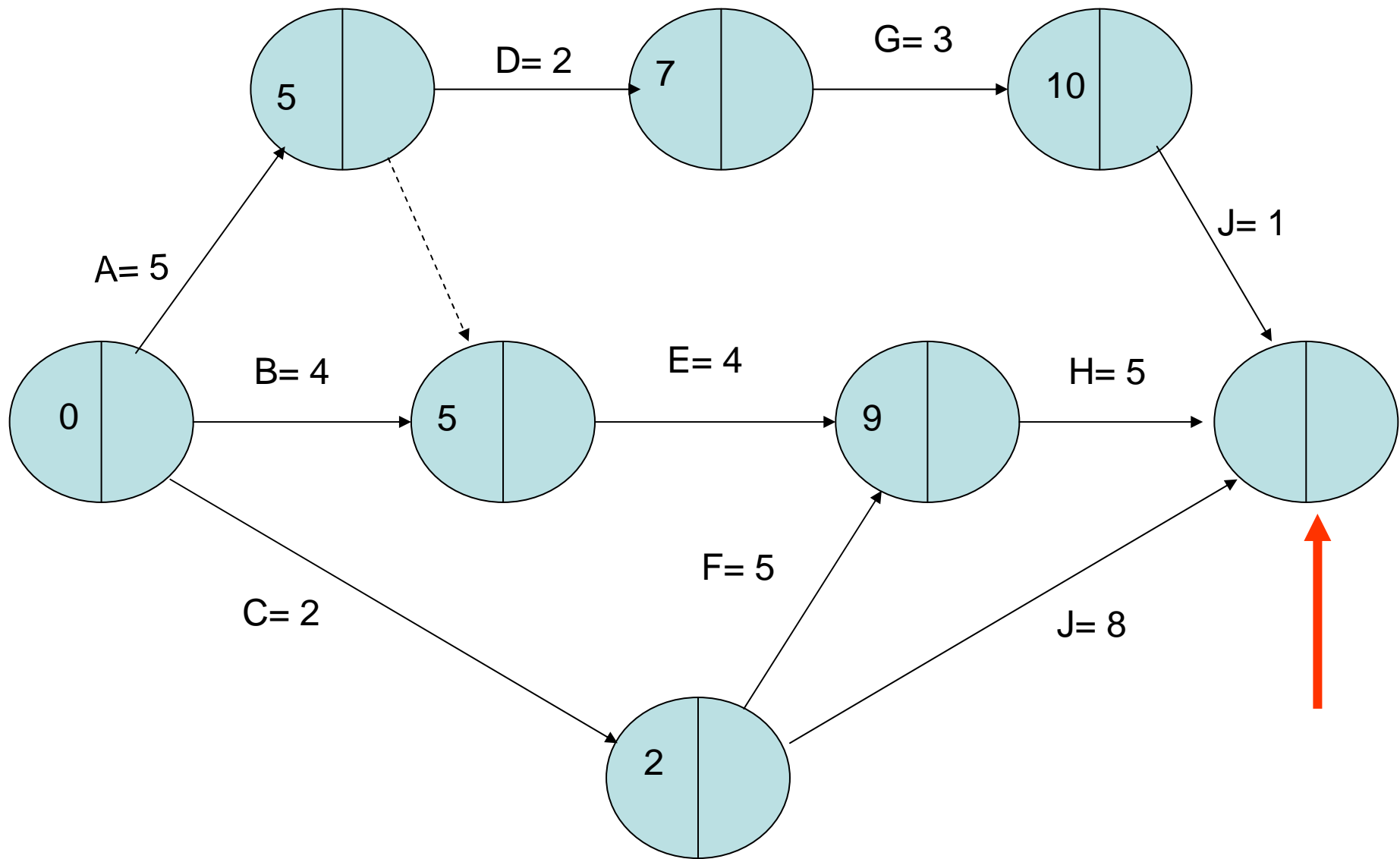

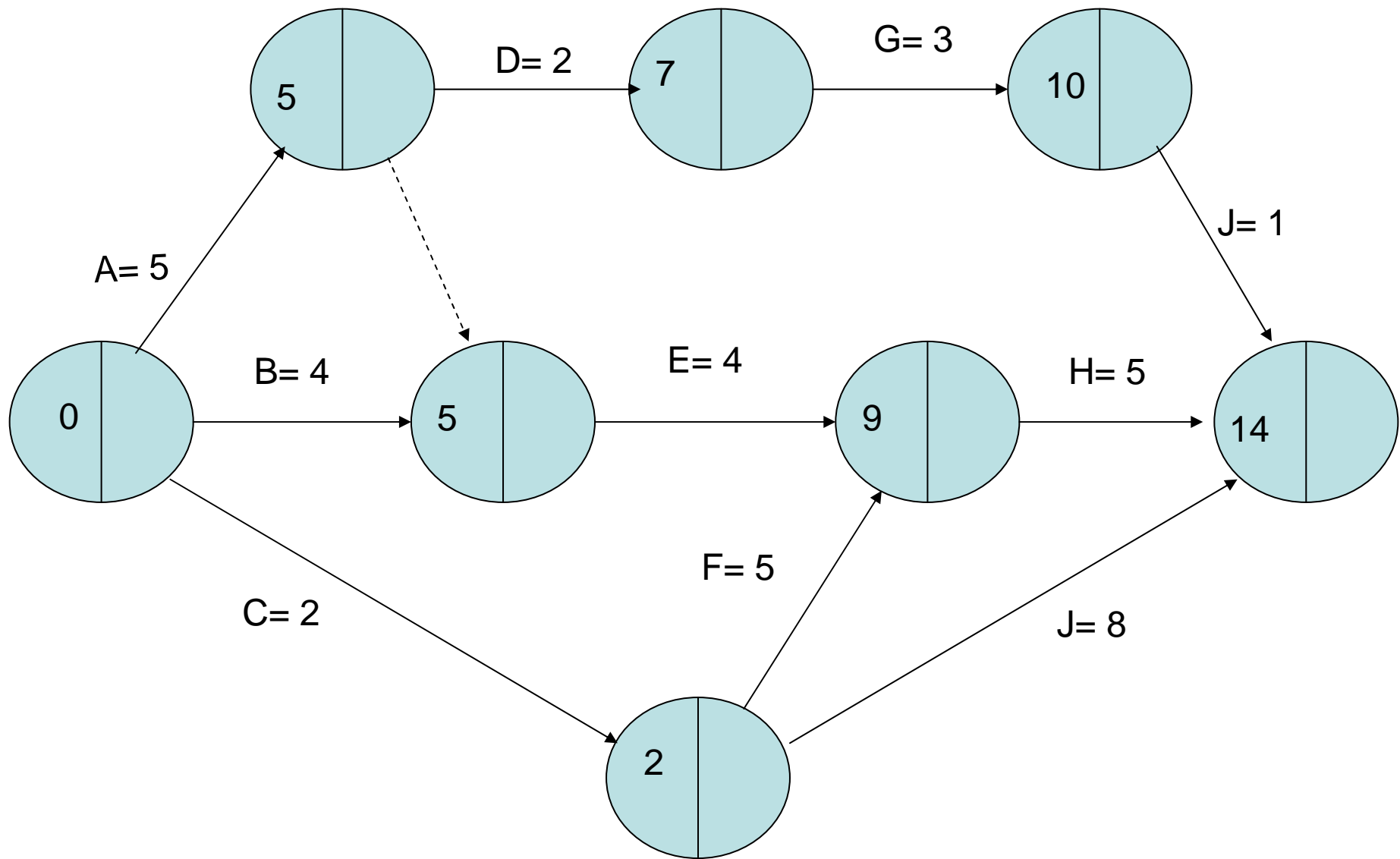

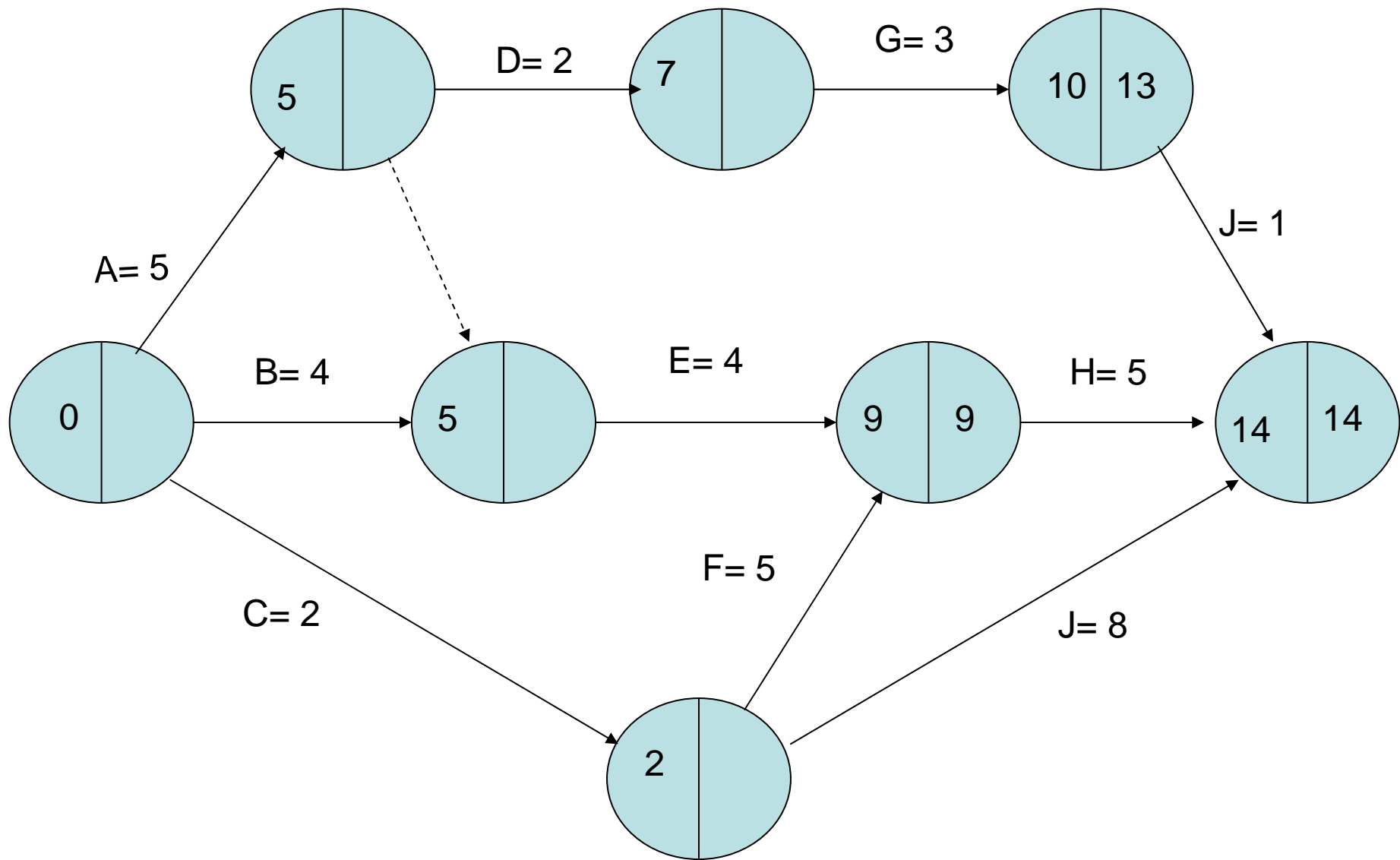

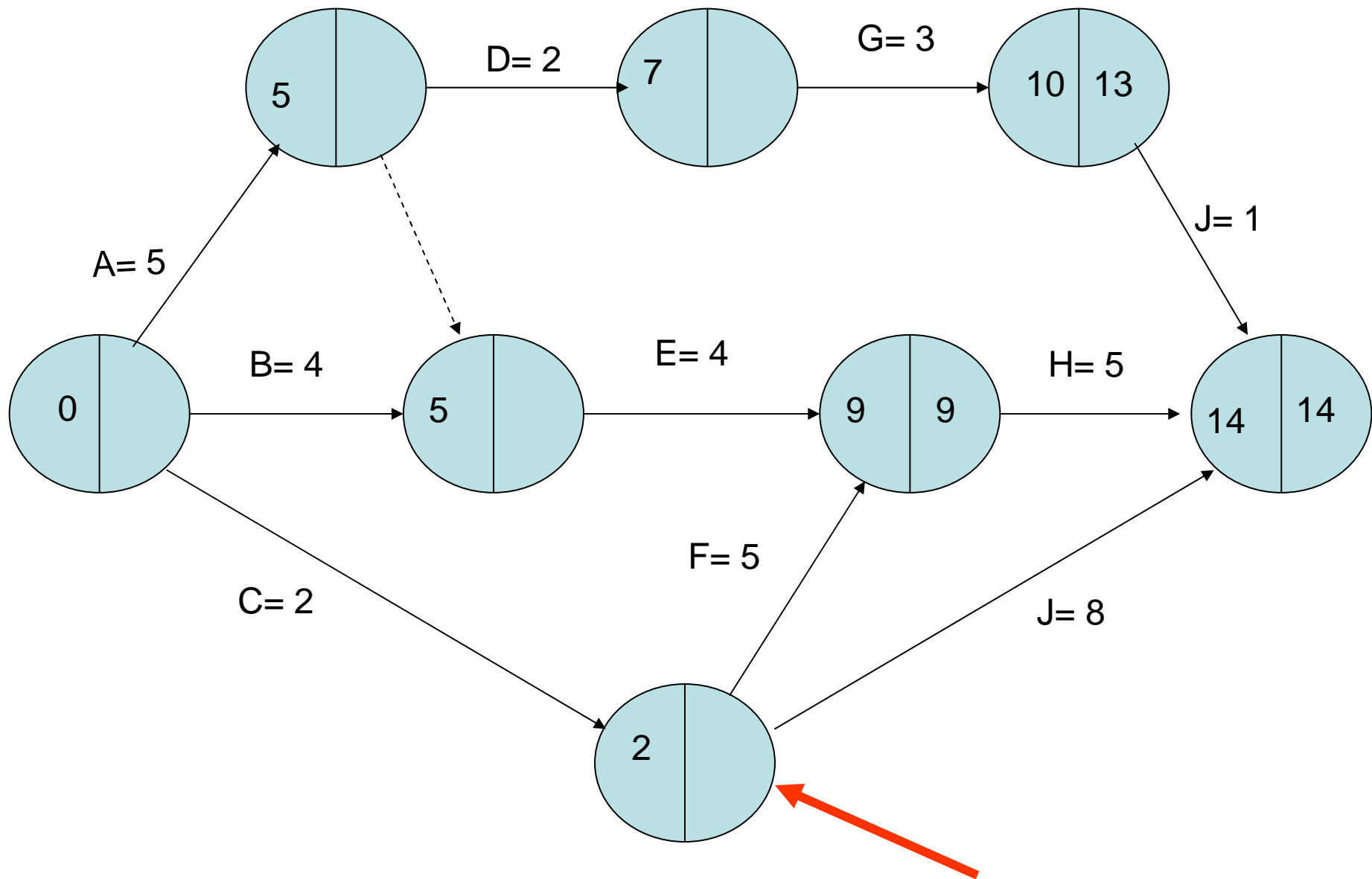

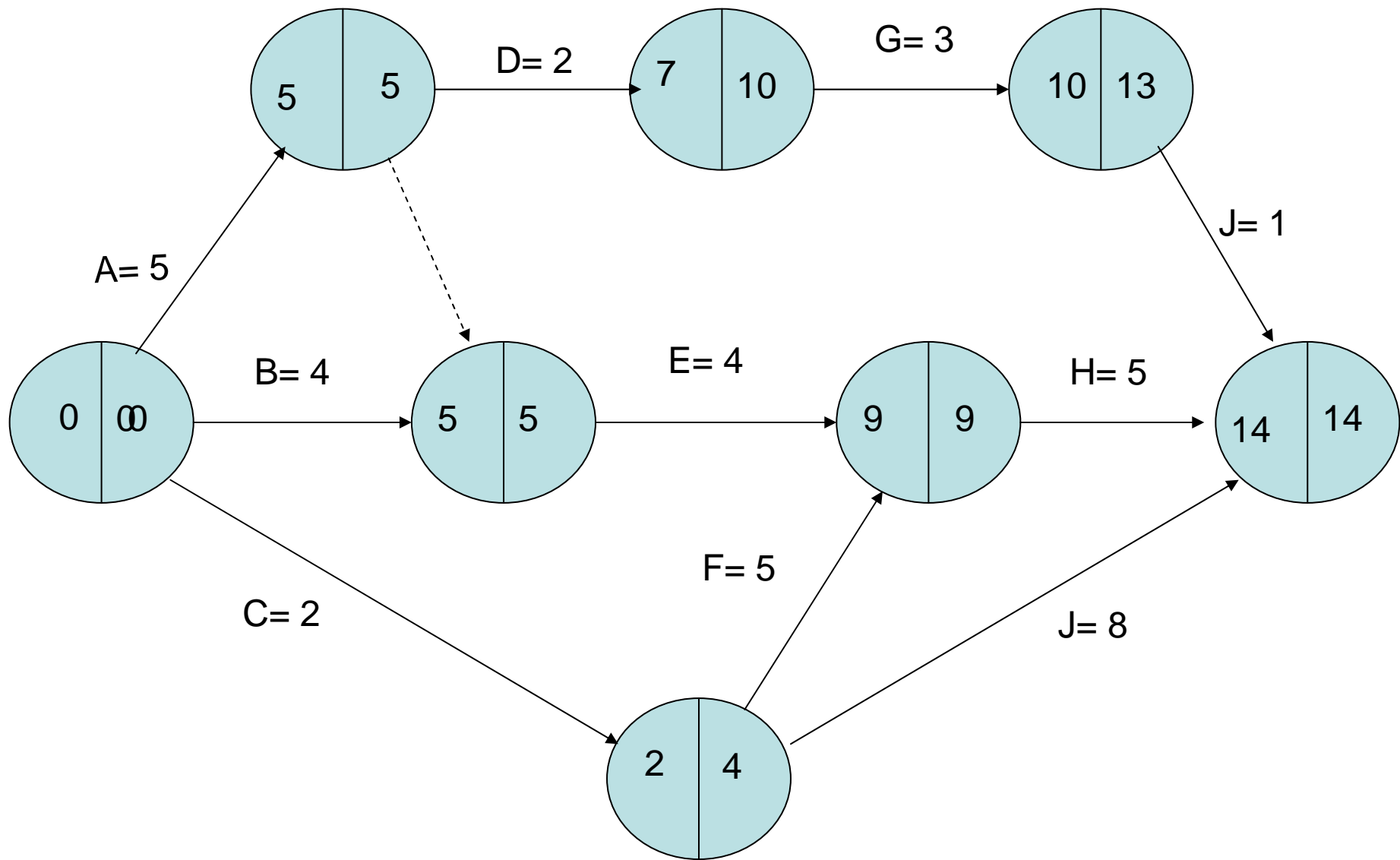

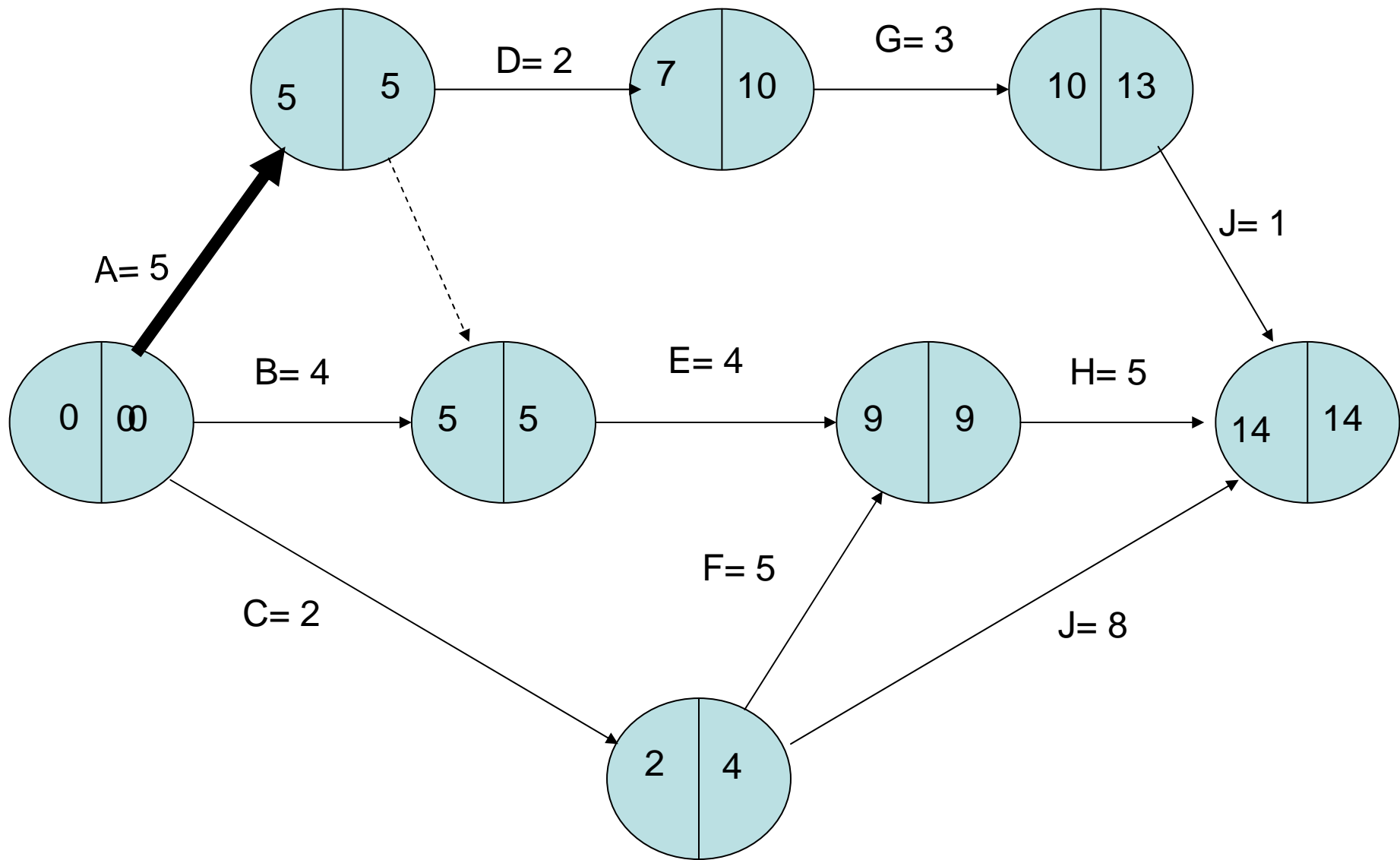

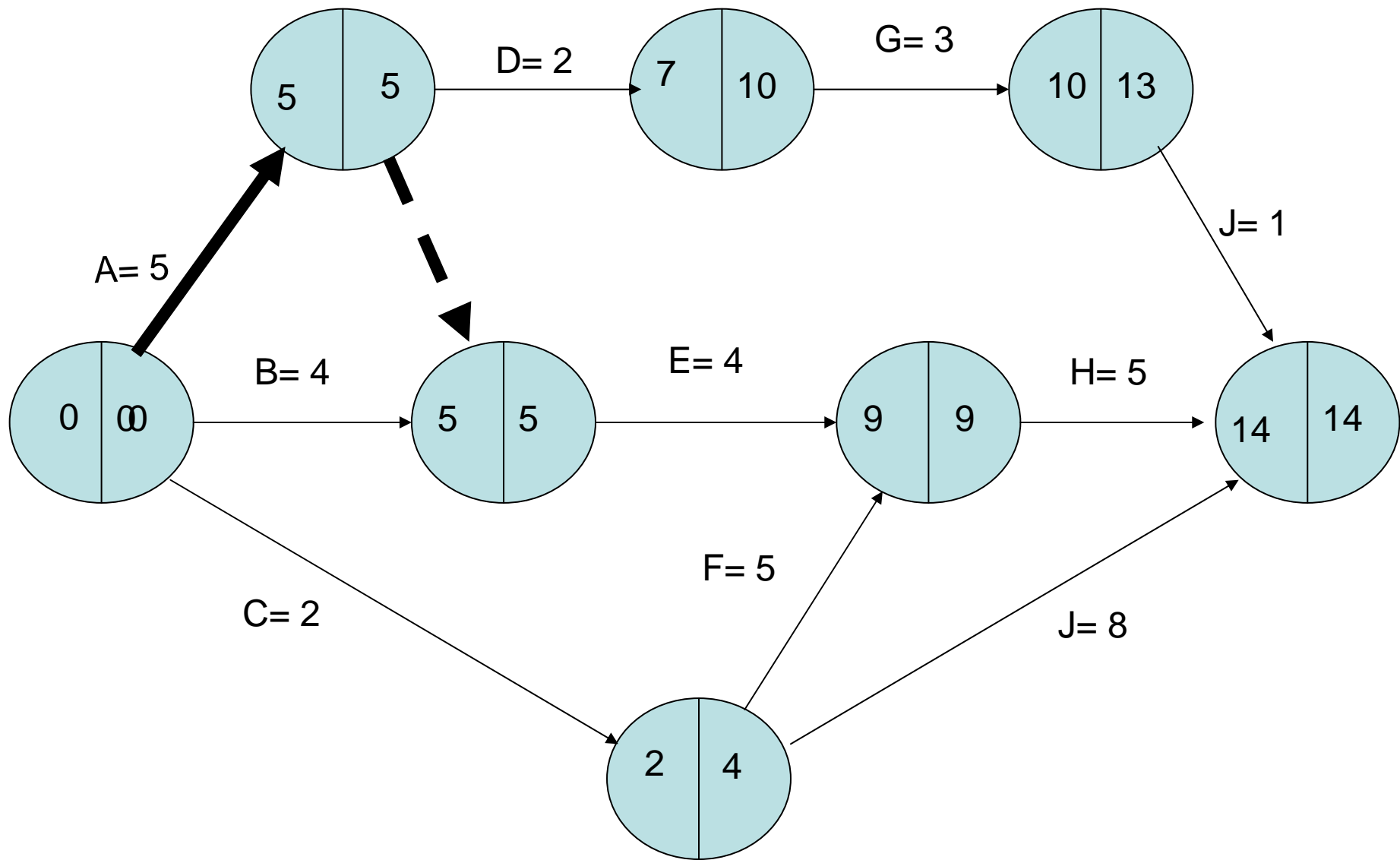

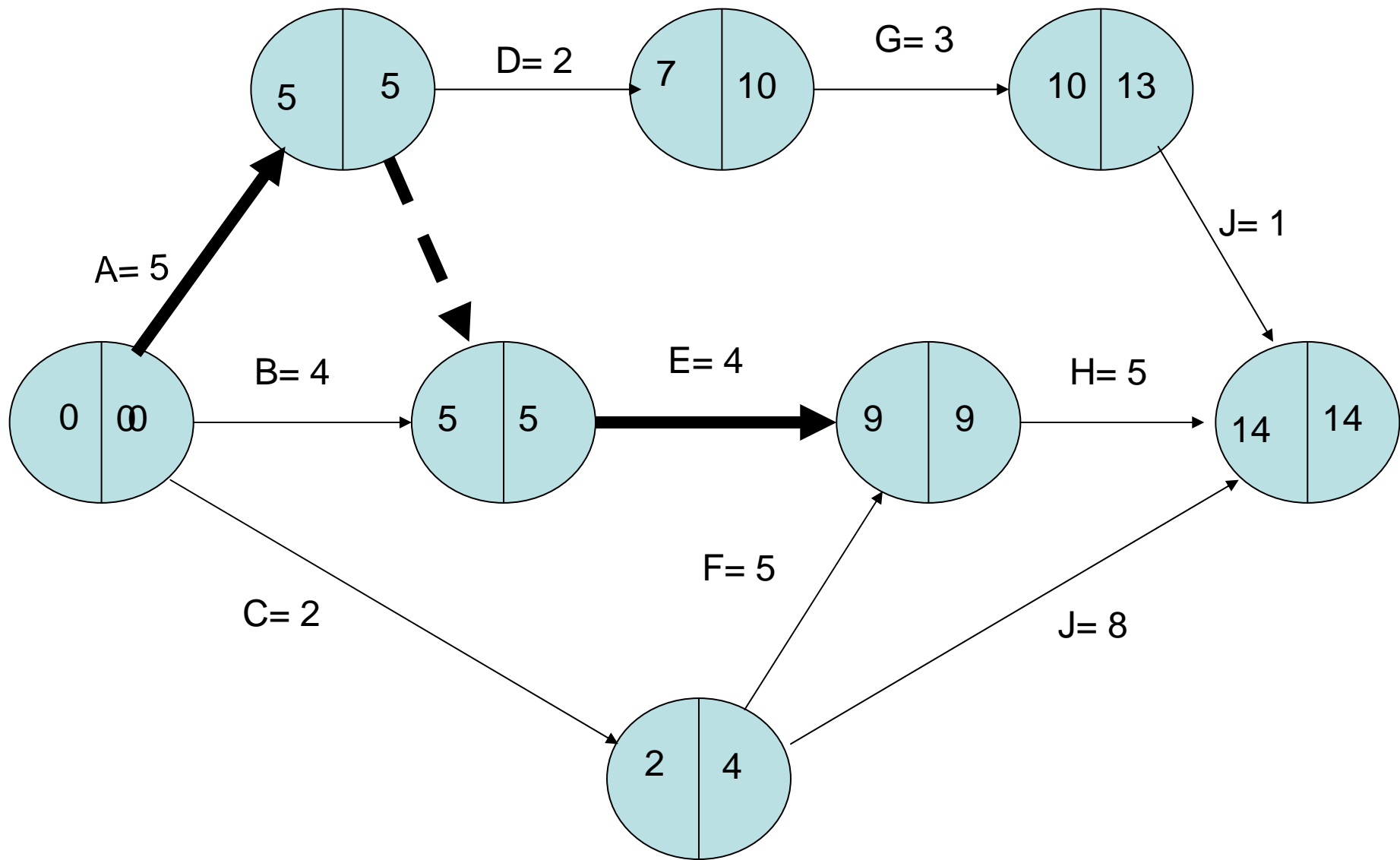

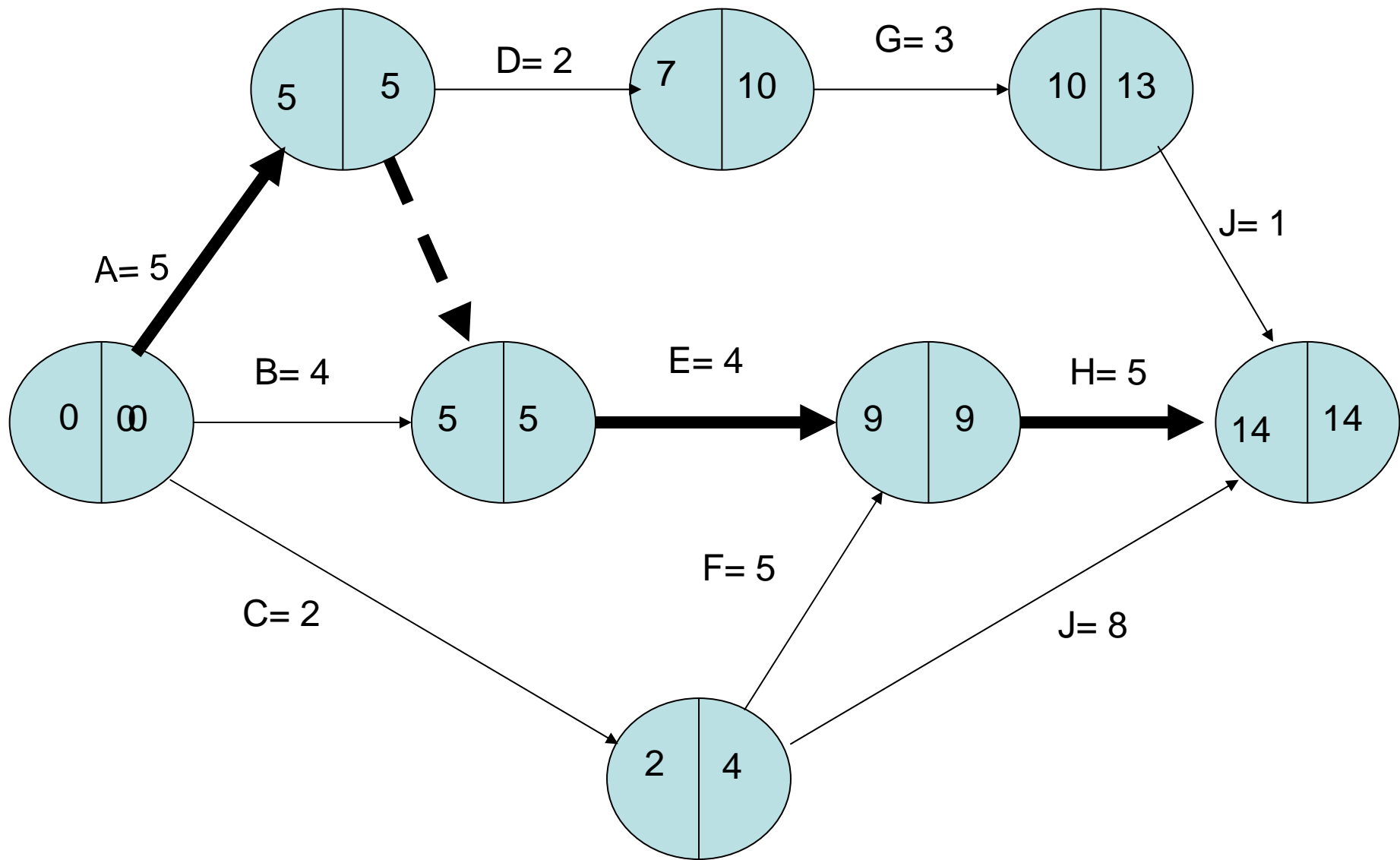

	1	2	3	4	5	6	7	8	9	10	11	12	13	14
A	11	11	11	11	11									
B	15	15	15	15										
C	35	35												
D						11	11							
E						12,5	12,5	12,5	12,5					
F			15	15	15	15	15							
G								10	10	10				
H										10	10	10	10	10
I											30			
J			10,5	10,5	10,5	10,5	10,5	10,5	10,5	10,5				
Inv.	61	61	51,5	51,5	36,5	49	49	33	33	30,5	40	10	10	10

	1	2	3	4	5	6	7	8	9	10	11	12	13	14
A	11	11	11	11	11									
B	15	15	15	15										
C	35	35												
D						11	11							
E						12,5	12,5	12,5	12,5					
F			15	15	15	15	15							
G								10	10	10				
H										10	10	10	10	10
I											30			
J			10,5	10,5	10,5	10,5	10,5	10,5	10,5	10,5				
Inv.	61	61	51,5	51,5	36,5	49	49	33	33	30,5	40	10	10	10

	1	2	3	4	5	6	7	8	9	10	11	12	13	14
A	11	11	11	11	11									
B	15	15	15	15										
C	35	35												
D						11	11							
E						12,5	12,5	12,5	12,5					
F			15	15	15	15	15							
G								10	10	10				
H										10	10	10	10	10
I											30			
J			10,5	10,5	10,5	10,5	10,5	10,5	10,5	10,5				
Inv.	61	61	51,5	51,5	36,5	49	49	33	33	30,5	40	10	10	10

	1	2	3	4	5	6	7	8	9	10	11	12	13	14
A	11	11	11	11	11									
B	15	15	15	15										
C	35	35												
D							11	11						
E						12,5	12,5	12,5	12,5					
F					15	15	15	15	15					
G									10	10	10			
H										10	10	10	10	10
I												30		
J							10,5	10,5	10,5	10,5	10,5	10,5	10,5	10,5
Inver.	61	61	26	26	26	27,5	49	49	48	30,5	30,5	50,5	20,5	20,5

Actuación:

D: la corro un lugar y sale del entorno 2/6

F: la corro dos lugares pues es toda su holgura

G: la tengo que correr un lugar pues sigue a “D” que la corrí

I: la tengo que correr un lugar porque sigue a “G” que la corrí

J: la corro cuatro lugares para sacarla del entorno 2/6

Consecuencias:

“F” y “J” se convierten también en críticas

	1	2	3	4	5	6	7	8	9	10	11	12	13	14
A	11	11	11	11	11									
B	15	15	15	15										
C	35	35												
D							11	11						
E						12,5	12,5	12,5	12,5					
F					15	15	15	15	15					
G									10	10	10			
H										10	10	10	10	10
I												30		
J							10,5	10,5	10,5	10,5	10,5	10,5	10,5	10,5
Inver.	61	61	26	26	26	27,5	49	49	48	30,5	30,5	50,5	20,5	20,5